

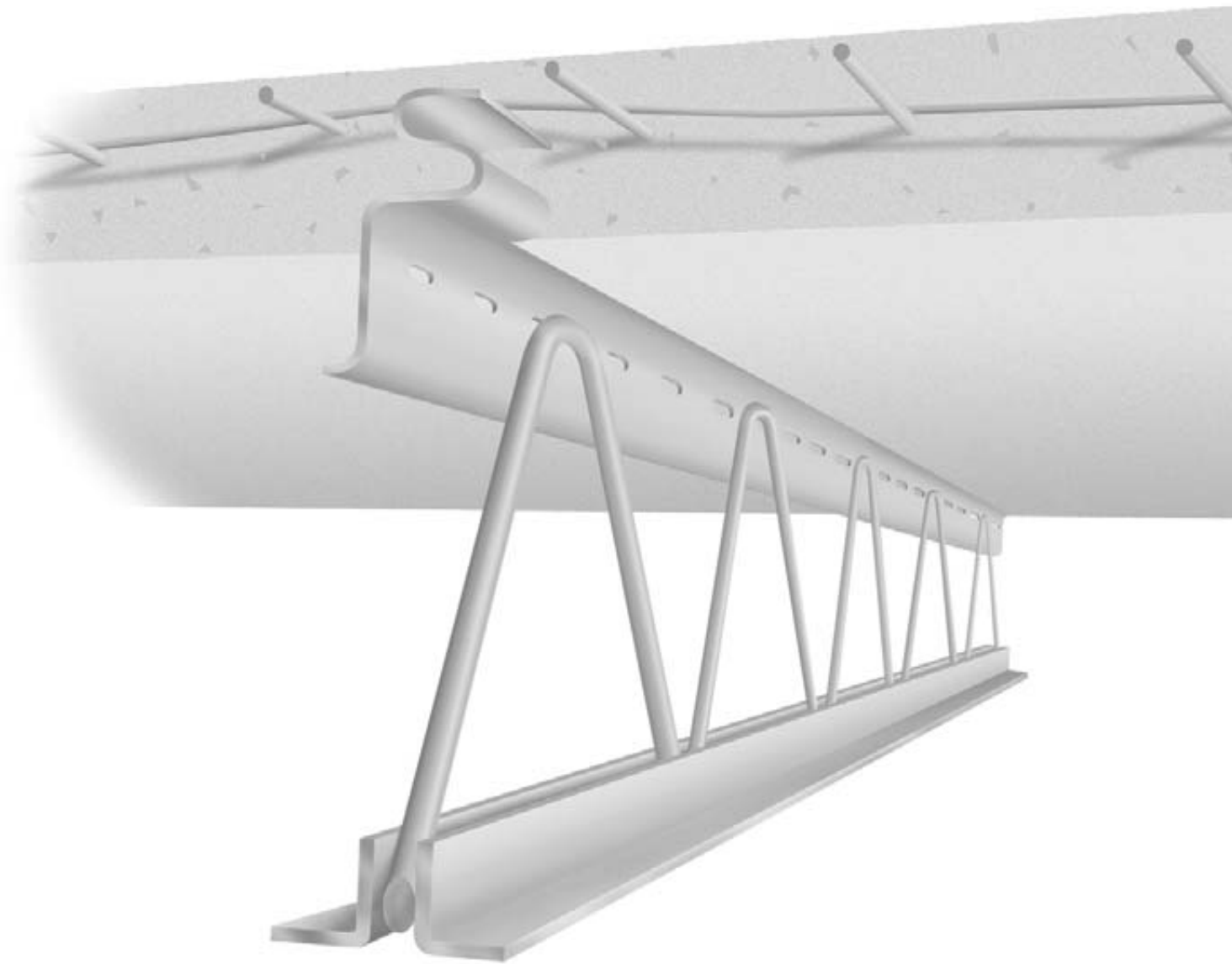

# Installation Manual



**HAMBRO**<sup>®</sup>  
Proven Concrete Floor System

[www.hambro.ws](http://www.hambro.ws)



# TABLE OF CONTENTS

	PAGE
1. OVERVIEW .....	3
2. INSTALLATION .....	5
3. DELIVERY, HANDLING AND STORAGE .....	6
4. INSTALLING THE JOISTS .....	8
5. ROLLBAR® TYPES .....	10
6. INSTALLING THE ROLLBAR® .....	11
7. PLACING THE REUSEABLE PLYWOOD FORMS .....	14
8. PLACING THE MESH .....	15
9. PLACING THE CONCRETE .....	16
10. STRIPPING OF FORMS .....	18
11. IMPORTANT NOTICES .....	19

This manual is provided as a basic guide of recommended techniques for the installation of the Hambro® Composite Floor System. It is not intended to take the place of the requirements of any local building codes. Local code requirements must always govern and be followed. Every actual installation must be made in accordance with the contract drawings, specifications, and approved installation drawings provided by your Hambro supplier. Accordingly, while these guidelines are intended as recommended general techniques to be followed, these techniques can be used only to the extent they do not conflict with applicable building code requirements and approved drawings and specifications. You are requested to contact your Hambro supplier for contradictions or conditions not clearly covered in this manual.

Canam and Design, and Red Dot Design are registered trademarks of Canam Group Inc.  
Hambro is a trademark of Hambro International (Structures) Ltd.

# 1. OVERVIEW

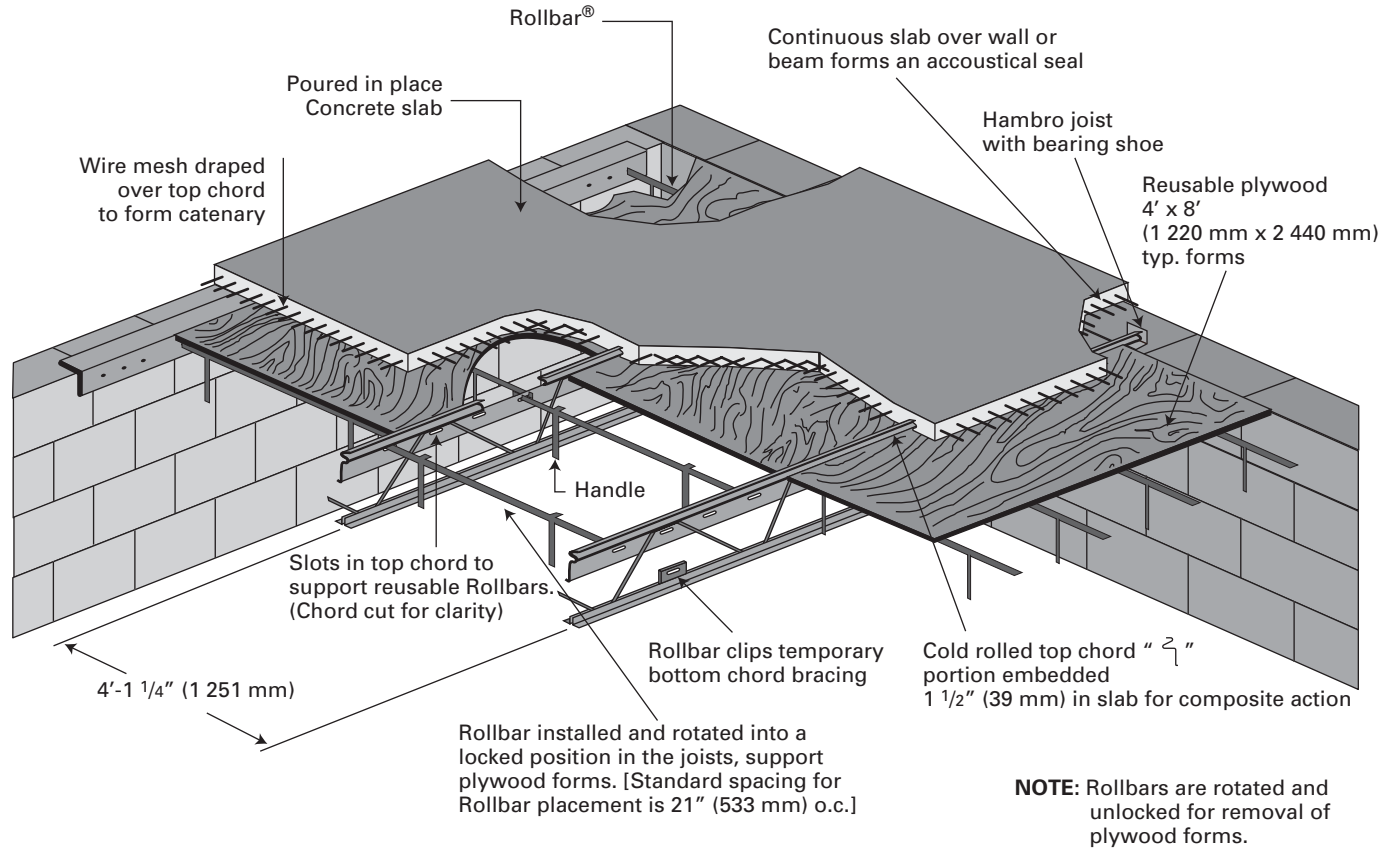

**CANADA PATENT N°:**  
874180

**U.S. PATENT N°s:**  
3818083 3819143  
3841597 3845594  
3913296 3945168  
3979868 4015396  
4584815 4729201

**OTHER U.S. & FOREIGN PATENTS PENDING**

# OVERVIEW

## 1. SPREADING THE JOISTS

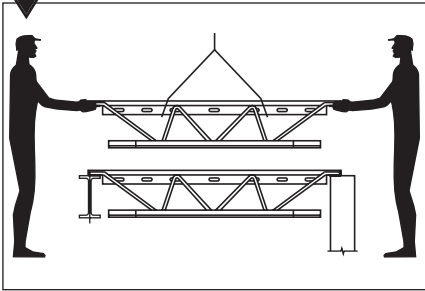

Bundles are placed on the walls or beams per Hambro® drawings and spread to approximately 4' (1 200 mm) on center. For modular construction, 5' (1 500 mm) spacing is available. Check your load conditions and fire ratings for permissible options

## 2. INSTALLING THE ROLLBAR®

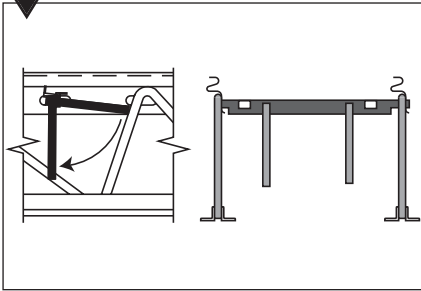

These Rollbars are designed to support the plywood forms and the slab dead weight plus a 40 psf (2 kPa) construction load. When rotated and locked into notches in the top chord, the Rollbars lock the joists in place while providing lateral and torsional stability.

## 3. INSTALLING PLYWOOD FORMS

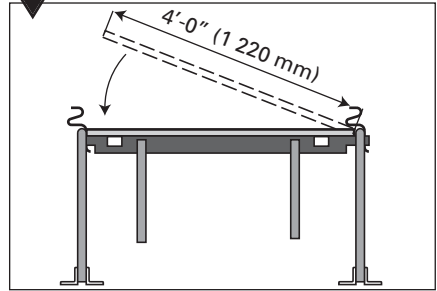

Together, the plywood and Rollbars form a rigid diaphragm during construction, providing a platform for your workforce. The Hambro system accommodates standard 4' x 8' (1 220 mm x 2 440 mm) plywood sheets. 3/8" (9.5 mm), 1/2" (12.7 mm) or 3/4" (19 mm) may be used. See installation detail on page 14.

## 4. GANG FORMING

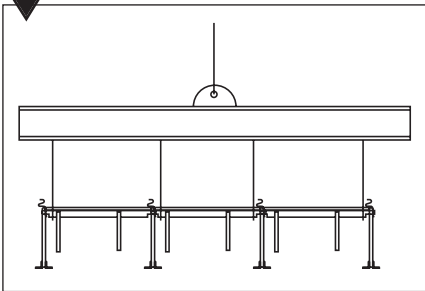

As an alternative to step 1 shown above, entire bays of Hambro can be pre-installed, locked in place with Rollbars, stored on the ground and later hoisted into place.

## 5. MESH IN PLACE

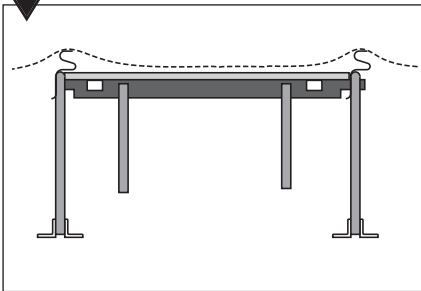

Standard 8' x 20' (2.4 m x 6.1 m) flat sheets of mesh are easily placed over the top chords of the Hambro joists. With the top chord acting as a highchair, the mesh forms a natural catenary to reinforce and support the concrete slab. No additional mesh support is required between the joists unless noted.

## 6. BOTTOM CHORD BRACING

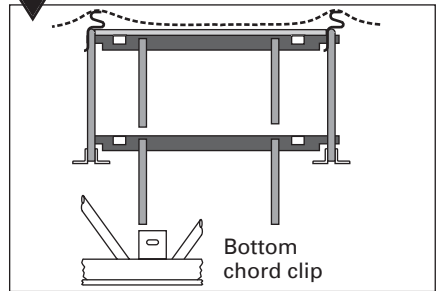

Bottom chords are fabricated with clips generally at third points to accommodate a Rollbar for temporary bracing during the concreting stage. No shoring is required unless noted. See installation detail on page 13.

## 7. POURING CONCRETE

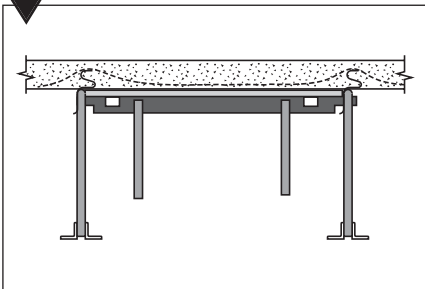

Minimum design practice calls for a 2 1/2" (65 mm)-3,000 psi (20 MPa) slab. The monolithic pour of the concrete slab will enhance the diaphragm action and forms an acoustical seal where the slab passes over the walls. The patented top chord protrudes into the slab for composite action, and serves as a guide for concrete placement.

## 8. STRIPPING FORMWORK

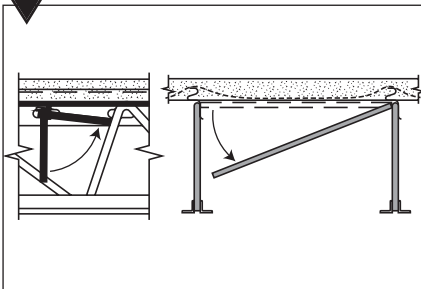

Rollbars and plywood forms are usually stripped the day after the pour or as soon as the concrete reaches 500 psi (3.5 MPa). The deck is ready for other trades when the concrete reached a strength of 1,000 psi (7 MPa), usually within 48 hours after the pour. The Rollbars and forms are easily removed for future re-use.

## 9. FURRING CHANNELS

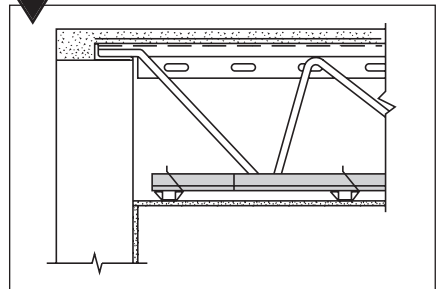

Furring channels are tied with wire to the bottom chord of the Hambro joists. Fire rated gypsum or acoustical board completes the assembly, providing an attractive continuous ceiling.

# 2. INSTALLATION

## TRAINING FOR INSTALLERS

Take two Hambro® joists and set them on supports spaced 4'-1 1/4" (1 251 mm) apart. Then take the standard Rollbar® and place 5 or 6 of these bars in position. Now, have your workmen stand between the two Hambro joists, continuously inserting and taking out the Rollbars for several minutes. This time invested will bring a rapid understanding of the installation of the Rollbars.

The Hambro installation breaks down into six simple steps:

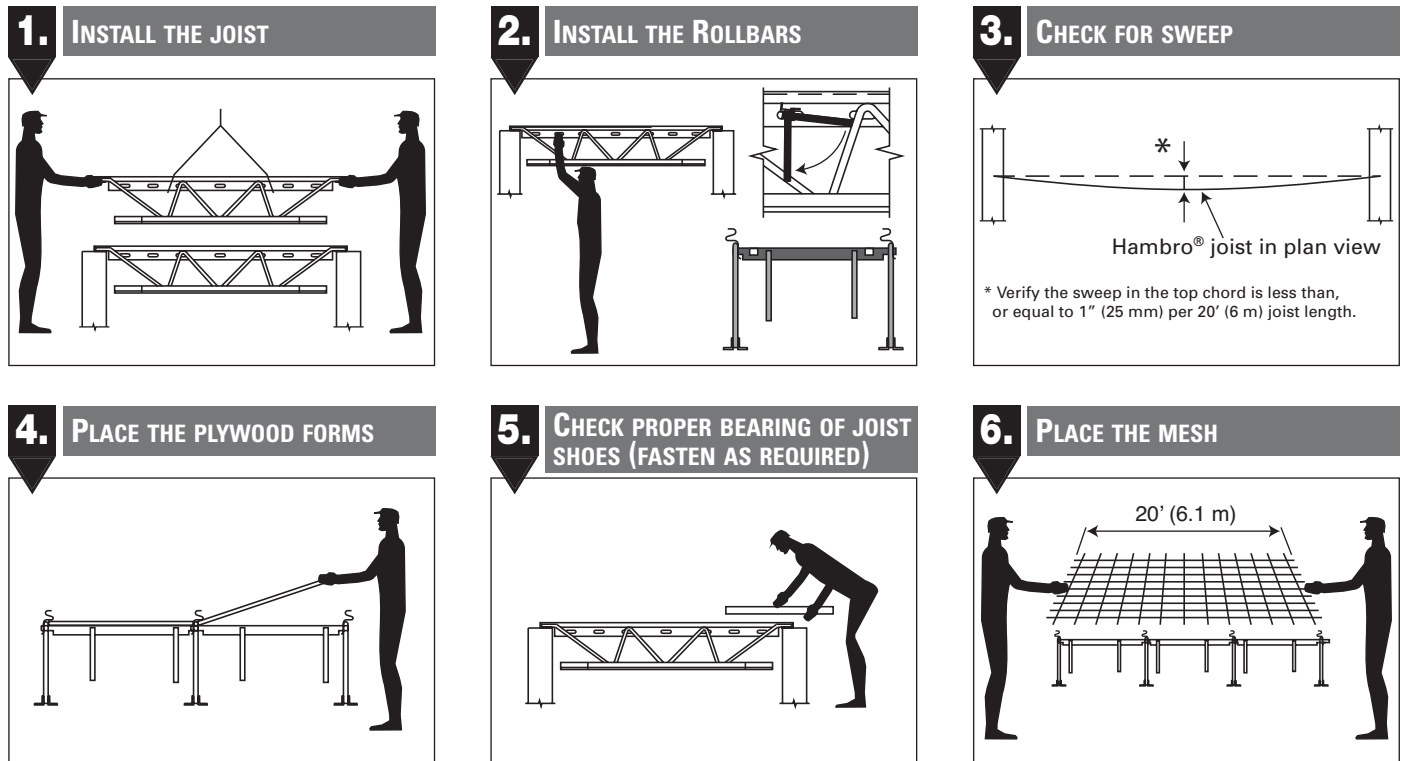

These steps create a simple flow of production that complements any construction schedule.

**NOTE:** After installation, permissible Hambro joist sweep shall be 1" (25 mm) in 20' (6 m).

## TOOLS

Few tools are needed to install Hambro, but be sure to have enough of the proper equipment available to keep all employees working.

Plan on having the following items available:

1. Sledge hammer for tapping and moving joist shoes to proper bearing position, and the plywood form under the joist seat and beam flange, if applicable.
2. Circular power saw.
3. Rolling scaffold for Rollbar installation, if required.
4. 4' (1 200 mm) rigid metal pipe for levering tight bars in and out (if needed).
5. Form oil and applicator for plywood.

# 3. DELIVERY, HANDLING AND STORAGE

## DELIVERY

Hambro® joists are delivered on a flatbed trailer, banded in nested bundles and tagged by job. Proper equipment should be provided for off-loading the material.

All material must be checked by the buyer and/or installer upon arrival at the job site, with discrepancies and damages promptly reported to your Hambro supplier at time of delivery.

**NOTE:** Hambro joists shall be fabricated with the following approximate cambers (based upon dead load design):

SPAN	CAMBER
10' (3.0 m) to 20' (6.1 m)	0" (0 mm) to 3/4" (19 mm)
20' (6.1 m) to 30' (9.1 m)	3/4" (19 mm) to 1 1/2" (38 mm)
30' (9.1 m) to 40' (12.2 m)	1 1/2" (38 mm) to 2" (51 mm)

## HOISTING

When hoisted by crane, the cables must be placed at third points and under the top chord of the joists, never attached to the web members.

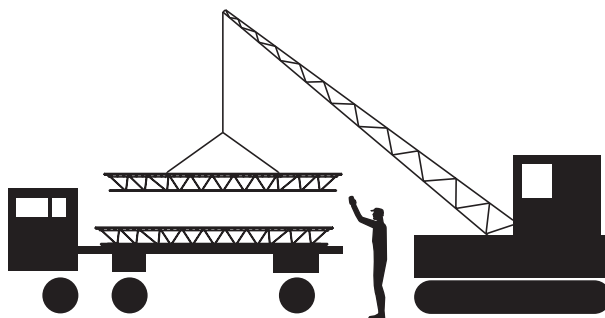

Diagram #1

## STORING

The Hambro joists must be stored upright on a level surface; to prevent damage, joists should not be stacked.

## DAMAGED JOISTS

Care should be exercised at all times to avoid damage through careless handling during unloading, storing and installing. Note, that damaged joists may impair the performance and safety of the system, and must be repaired or replaced prior to installation.

**DO NOT MAKE FIELD REPAIRS TO DAMAGED HAMBRO JOISTS WITHOUT WRITTEN APPROVAL FROM YOUR HAMBRO SUPPLIER AND STRUCTURAL ENGINEER OF RECORD. HAMBRO WILL PROVIDE A REPAIR DETAIL AT NO CHARGE TO OUR CUSTOMERS.**



## ROLLBAR® DELIVERY

The Rollbars will be delivered to the job site in racks or bundles per type. Upon job completion, all rollbars are to be sorted by type and placed back in racks or bundles for pickup.

## JOIST IDENTIFICATION

The Hambro® joist is tagged with an identification plate attached at one end, at the joist shoe.

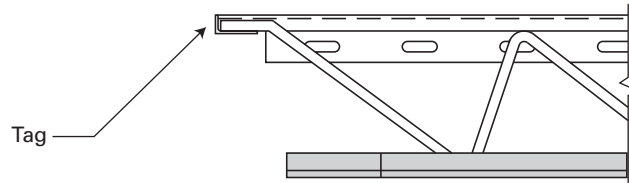

Diagram #2

# 4. INSTALLING THE JOISTS

## TYPICAL SPACING

Hambro® joists are typically spaced at 4'-1 1/4" (1 251 mm) o.c. To start the installation procedure, space them approximately 4' (1 200 mm) o.c. on the bearing provided. Typical Hambro spacing may also be 5'-1 1/4" (1 555 mm) nominal. For the sake of simplicity, in this manual the standard spacing will be 4'-1 1/4" (1 251 mm).

## FOUR POINTS WHERE EXTRA CARE SHOULD BE TAKEN

**A. Direction of Top Chord:** It is necessary that all top chords face the same direction within a section of Hambro slab. As you will note from diagram #3, the forms butt on one side of the top chord, but tuck under on the opposite side in order to facilitate the stripping of the plywood. See the installation drawings for orientation and placement of the tagged I.D. end with respect to the bearing location. If the joists are not installed as indicated, forms will not fit properly (the plywood forms will be too wide or too narrow to suit the joist spacing).

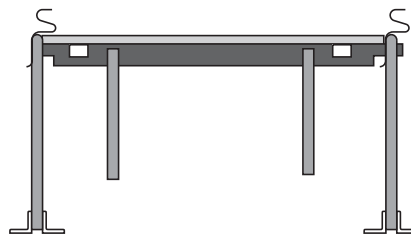

Diagram #3

**B. Special joists** will determine the direction of the top chord. Before you start installation, determine proper direction of top chords from joists that have special conditions (i.e. deep shoe (DS), hanger plate (HP), point load reinforcing (PL). Study the Hambro installation drawings for special conditions and follow the position of the tagged ends for proper orientation of joists. A little care at the start will eliminate the additional cost of removing bars and reinstalling joists.

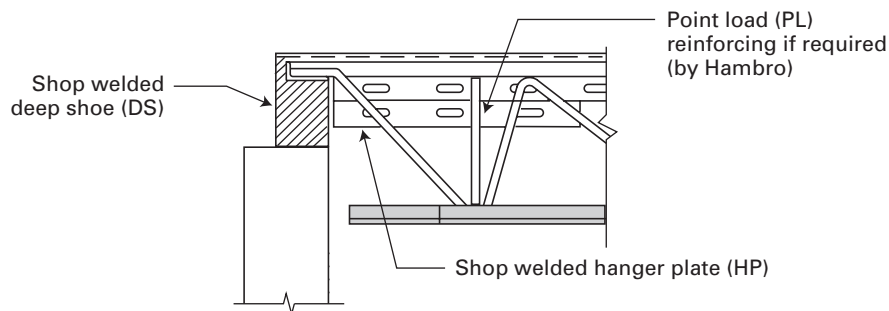

Diagram #4

# INSTALLING THE JOISTS

**C. End joists:** A close measurement shall be taken on the first joist that is set, usually the one next to the wall, beam, or tie joist. Careful measurement of this spacing, which is usually a little larger or smaller than the standard 4'-1 1/4" (1 251 mm) spacing, will save unnecessary shifting of the system. All measurements should be taken nominally to the centerline of the joists.

**D. Bearing:** It is important to make sure that the joist shoes are placed properly on the supporting walls or beams. Joists should be centered so you get **equal bearing** for the shoes. The minimum bearing on masonry, concrete, metal studs or wood support is 3 1/2" (90 mm). The minimum bearing on structural steel is 2 1/2" (65 mm), unless noted otherwise. **REDUCED BEARING COULD PRESENT A SAFETY HAZARD.** As soon as the Hambro® joist is installed, the Rollbar® shall be installed. Particular attention should be paid to the installation of long Hambro joists; each joist shall be adequately braced with the Rollbars before the next joist is installed.

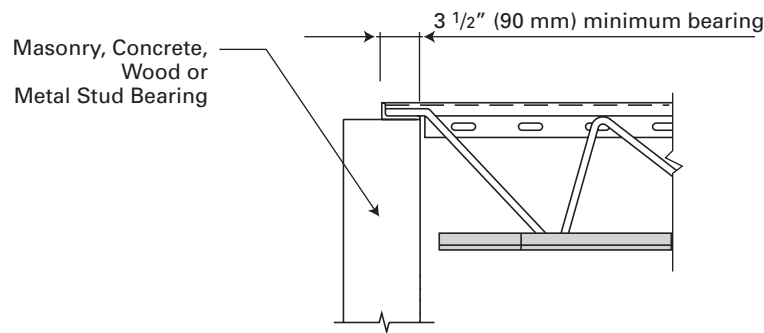

Diagram #5

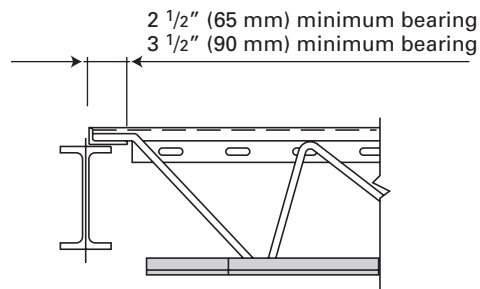
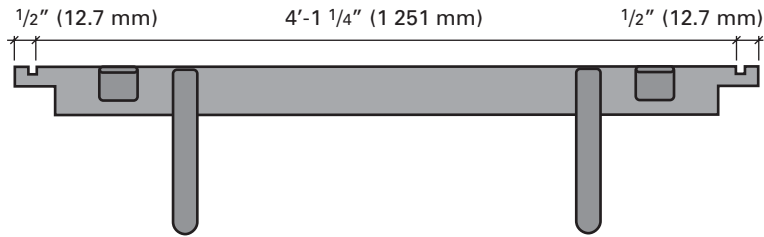

Diagram #6

# 5. ROLLBAR® TYPES

## SRB - STANDARD ROLLBAR®



## TRB 1 - TELESCOPIC ROLLBAR® 1

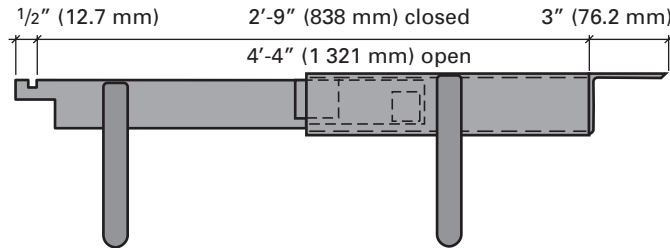

## TRB 2 - TELESCOPIC ROLLBAR® 2

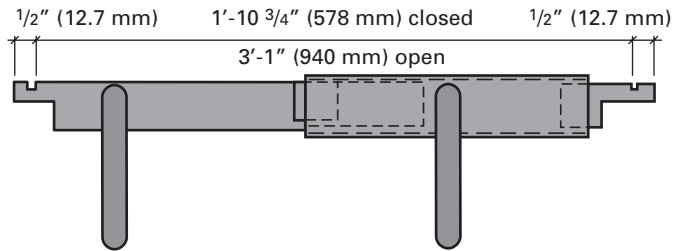

## TRB 3 - TELESCOPIC ROLLBAR® 3

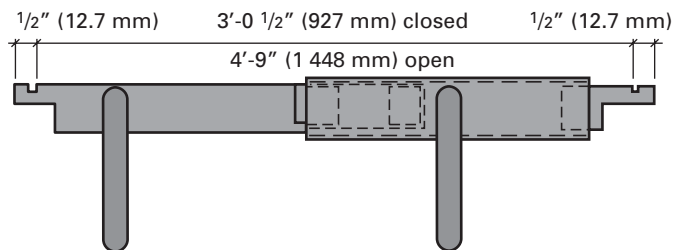

## EFB 1 - EDGE FORMING BAR 1

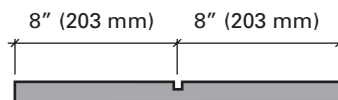

## 6. INSTALLING THE ROLLBAR®

Slots in the top chord are  $\frac{5}{8}$ " x  $1\frac{3}{4}$ " (16 mm x 44 mm) and spaced 7" (178 mm) o.c. The first Rollbar at the end of the joist, nearest the beam or wall, must be installed with the handles and the angle clips facing the wall and the flat surface of the bar must come in contact with the plywood form.

### SPACING

In order to support forms properly, care should be taken to install the Rollbars at 21" (533 mm) o.c., for the usual  $2\frac{1}{2}$ " (65 mm) - 4" (100 mm) slab, but never greater than 28" (712 mm) o.c. Exceeding this dimension would be dangerous, since it overloads the bars and plywood. IMPROPER SPACING OF ROLLBARS MAY AFFECT THE STRUCTURAL SAFETY OF THE SYSTEM DURING THE CONCRETING STAGE. There should be a Rollbar as close to 7" (178 mm) from the end of each plywood form as field conditions permit. In the event that this is not possible, one alternate which has proven to be successful in preventing the ends of the forms from deflecting under the imposed construction load is shown in Diagram #7. (Unless superseded by local conditions.)

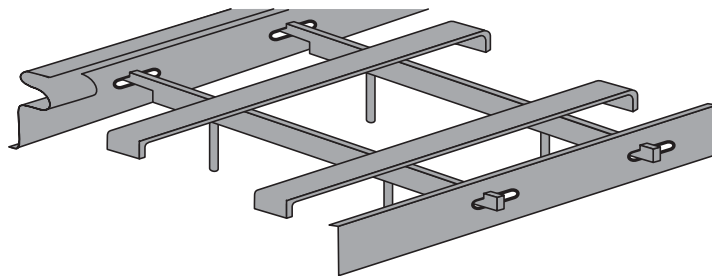

Diagram #7

For "L" up to  $1'-10\frac{3}{4}$ " (578 mm), forms are to be supported by  $\frac{1}{2}$ " (12.7 mm) or  $\frac{7}{16}$ " (11.1 mm) diameter steel rods or bars which fit into the slotted top chord, see Diagram #8.

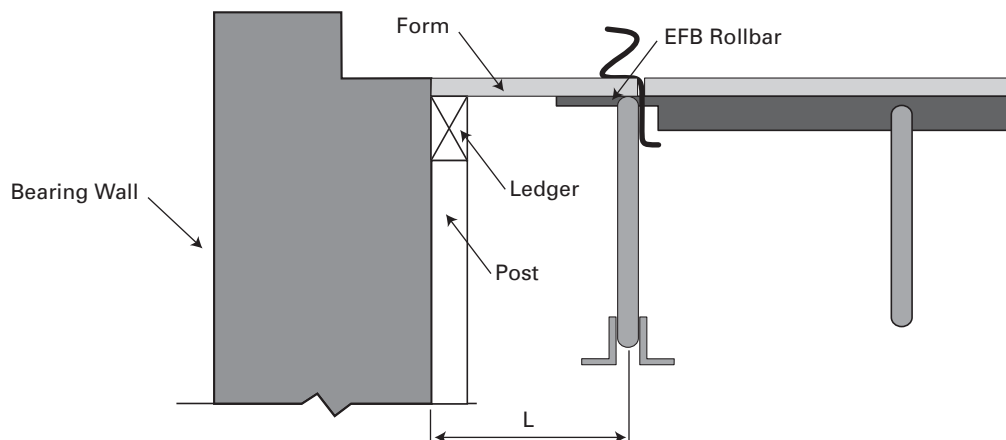

Diagram #8

# INSTALLING THE ROLLBAR®

## THICKENED SLABS

In the areas where thicker concrete slabs are specified, the Rollbar® should be installed at closer intervals. Where certain areas have been thickened and a hanger plate (HP) is used, they should not be spaced more than 14" (356 mm) o.c. for 4" (100 mm) to 6" (150 mm) slabs and 7" (178 mm) o.c. for slabs greater than 6" (150 mm).

SLAB THICKNESS	ROLLBAR SPACING
2 1/2" to 4" (65 mm to 100 mm)	21" C/C (533 mm C/C)
4 1/4" to 6" (108 mm to 150 mm)	14" C/C (356 mm C/C)
6 1/4" & MORE (158 mm & MORE)	7" C/C (178 mm C/C)

Table #1

## STAGGER ROLLBAR SPACING

Stagger the bars from bay to bay, whenever possible, so that only one Rollbar end is in each slot. This will simplify the stripping procedure. This does not apply to the temporary bottom chord bracing or the first Rollbar nearest the supporting wall or beam.

## TEMPORARY TOP CHORD BRACING

Rollbars inserted into the horizontal slots of the top chord not only provide a platform for the plywood forming, but also act to stabilize the joists. At end bays, or along load bearing surfaces, the Rollbars are inserted into slots in Rollbar Angle (RA). If no wall or structural frame is present, brace the top chord to the floor or grade as shown in Diagram #10.

## TEMPORARY BOTTOM CHORD BRACING

To provide additional stability during concreting, a Rollbar® shall be inserted in the clips that are welded to the bottom chords of the joists. This temporary bracing is removed when stripping the forms as it is not required at the composite stage. Bottom chord bracing shall be firmly braced to stable walls or main structural frame i.e. a 2" x 4" (50 mm x 100 mm) braced from the bottom chord angles to the end wall or beam as shown in Diagram #9.

**NOTE:** Bracing must be continuous at bottom chords to insure that all joists remain vertical. At end joist, where no wall or structural frame is present, brace the bottom chord to the floor or grade.

To prevent lateral movement of the top chords during construction, the lateral support provided by the regular 4'-1 1/4" (1 251 mm) slotted Rollbar must be carried through to the end walls or beams. When TRB's are used, due to odd spacing of the joists, positive spreaders must be spaced at 1/4 points [i.e. a 2" x 4" (50 mm x 100 mm) cut to exact length]. See diagram #9.

**NOTE:** Plywood forms ripped to exact width will also provide the required lateral support.

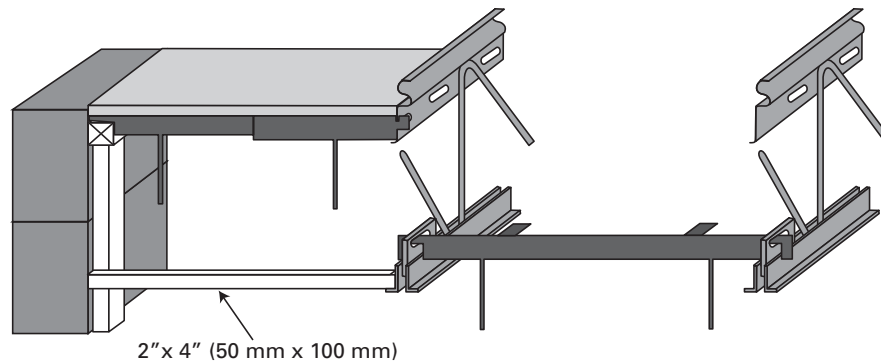

Diagram #9

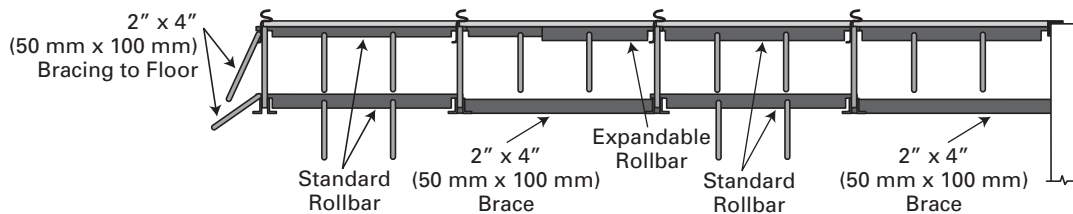

Diagram #10

# 7. PLACING THE REUSABLE PLYWOOD FORMS

## PLYWOOD TYPES

The standard spacing 4'-1 1/4" (1 251 mm) is designed to accept a standard 4' x 8' (1 220 x 2 440 mm) sheet of 3/8" (9.5 mm) or 1/2" (12.7 mm) plywood. When using 3/8" (9.5 mm) plywood, it is not necessary to butt the forms. They may be overlapped. When using 1/2" (12.7 mm) plywood, all joints must be butted since the double thickness would encroach into the area of the top chord that is designed to be imbedded into the concrete. Grade CDX is acceptable. If 3/4" (19 mm) plywood forms are desired, verify acceptable performance prior to initial use.

## END BAY CONDITION

When placing the plywood forms next to the end joist, be sure to avoid having the plywood sit on the bearing wall or beam. You will find that a form, bonded between the concrete pour and the bearing, is no longer removable and has to be chopped out. (see Diagrams #11 & #12)

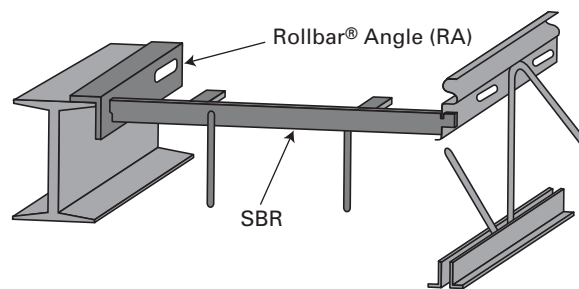

Diagram #11

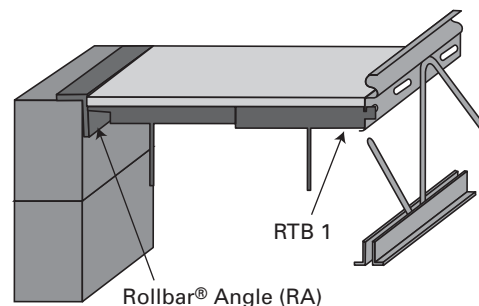

Diagram #12

Oiling the plywood as required prior to installation will save labor in stripping and will also prolong the useful life of the forms.

## CAUTION

1. Before any plywood forms are placed, there should be at least 3 standard spaced joists set (see Top & Bottom Chord Bracing on Page 13) with all the bars installed to safely develop the structural capacity of the Hambro® joists.
2. Full sheets of plywood are recommended. When shorter pieces are used, make sure they are adequately supported and safe for workers and construction loads.
3. Bundles of plywood or Rollbar racks should be placed on supporting walls or beams, never on the joist system. The system is not designed for this condition, and this will present a serious **SAFETY HAZARD**.

## 8. PLACING THE MESH

FLAT 8' x 20' (2.4 m x 6.1 m) SHEETS of plain welded wire mesh are recommended instead of rolled mesh for its ease of handling, and because it lays more naturally without ends sticking up.

### LAPPING

Be sure to get the minimum lap in both directions. Also be sure the mesh sits on the perimeter beams or walls at least 4" (100 mm) in order to develop the capacity of the slab, see Diagram #13 - Mesh Lapping.

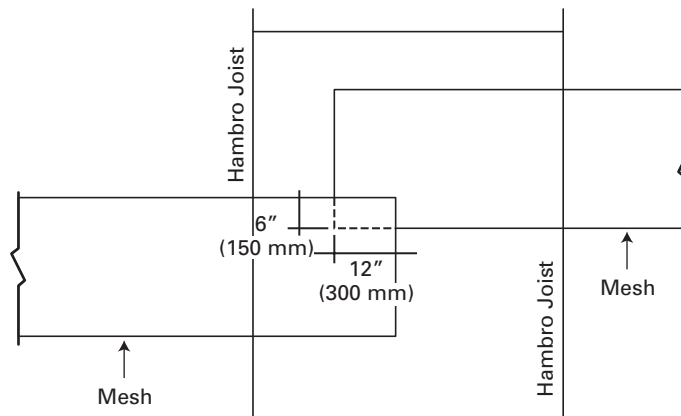

Diagram #13

Unless otherwise noted on the approved installation drawings or final contract drawings a single layer of mesh is all that is required.

Always check approved installation drawings and follow the contract drawings for slab reinforcement.

The flat sheets of mesh should drape naturally to the desired location and as noted in Diagram #14. Do not step down the mesh on either side of the top chord.

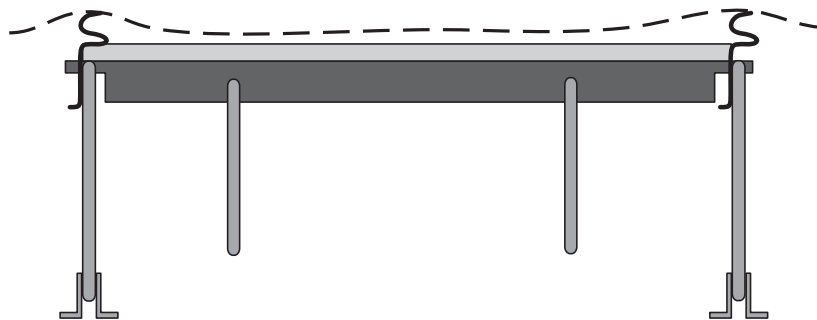

Diagram #14

# 9. PLACING THE CONCRETE

## CONCRETE MIX

The minimum compressive concrete strength is 3,000 psi (20 MPa). The aggregate in the concrete mix should not be greater than 3/4" (19 mm).

## SLUMP

Field experience indicates a 4" (100 mm) to 5" (125 mm) slump at the slab is easy to work with and finish. Greater slumps will create excessive leakage and cleanup.

## CAUTION:

TOO HIGH A SLUMP REDUCES THE STRENGTH OF THE CONCRETE AND CAUSES EXCESSIVE SHRINKAGE CRACKS.

## PLACING

When placing the concrete, maintain a depth of 1" (25 mm) minimum above the top chord for a nominal 2 1/2" (65 mm) slab. You will notice the joists are fabricated with a positive camber to offset the deflection caused by the weight of the concrete. It will come out as the slab is poured, leaving a small residual camber for additional dead load.

**NOTE:** Hambro joists shall be fabricated with approximately the following cambers\*:

SPAN	CAMBER
10' (3.0 m) to 20' (6.1 m)	0" (0 mm) to 3/4" (19 mm)
20' (6.1 m) to 30' (9.1 m)	3/4" (19 mm) to 1 1/2" (38 mm)
30' (9.1 m) to 40' (12.2 m)	1 1/2" (38 mm) to 2" (51 mm)

\*Based upon dead load design.

## VIBRATING

The concrete shall be **lightly but thoroughly vibrated** to ensure:

1. The full encasement of the top chord in the concrete (letting the vibrator lightly hit the top chord will ensure encasement). This is important in order to obtain the full design capacity of the system.
2. The elimination of "honeycombs".
3. That proper concrete cover is provided under the mesh.

## FINISH AND CURING

Work procedures shall be in accordance with the latest ACI requirements.

# PLACING THE CONCRETE

## CONSTRUCTION JOINTS

When pouring and finishing a deck, it is not necessary to complete the entire deck monolithically. If it becomes necessary to stop the pour parallel to the joists, the joint should be midway between the joists, but never closer than 6" (150 mm) to the top chord.

Construction joints perpendicular to the joists should be made over the supporting wall or beam.

**All concrete work should follow ACI guidelines.**

## SAFETY PRECAUTIONS WHEN POURING CONCRETE

The following 5 steps should be followed before and during the concrete pour to ensure a safe operation:

1. Check that all the Rollbar® and joists remain in the proper position prior to and during the pour.
2. As previously mentioned, reduce the spacing of the Rollbars if the slab thickness is greater than 4" (100 mm).
3. Check the plywood forms prior to and during the pour to be sure they are properly lapped or butted and that the plywood or any other material has not moved or covered the top chord.
4. During the pour, care should be taken not to subject the joists to excessive construction loads. Otherwise, the performance and safety of the system may be impaired. Do not pour concrete in excess of slab thickness specified on drawings, and do not drop large bucket loads in a concentrated area.

### Reminder

- Construction load for Rollbars is 40 psf (2 kPa)
- Construction load for joists is 20 psf (1 kPa)

5. The Rollbar is not designed to support buggies; therefore, runways must be placed on the top chord. This is usually accomplished with wood planks 2" x 12" (50 mm x 300 mm), placed perpendicular to the top chord.

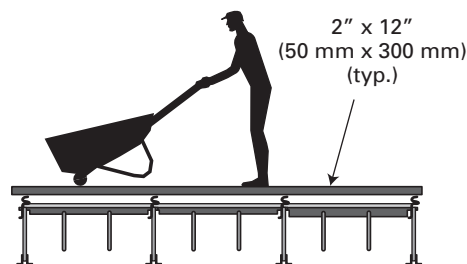

Diagram #15

## 10. STRIPPING OF FORMS

When the concrete attains a cylinder strength of 500 psi (3.5 MPa), you may remove the bars and plywood forms. When the concrete attains a cylinder strength of 1,000 psi (7 MPa), the deck is ready for work. Care should be exercised not to overload the system.

Avoid dropping the plywood forms when stripping. This causes damaged corners and edges, and greatly reduces the amount of re-use.

Also avoid dropping a Rollbar® on the slab, as this may cause chipping of the concrete surface.

Re-rack the bars by type. Place the racks where they are accessible for pick-up.

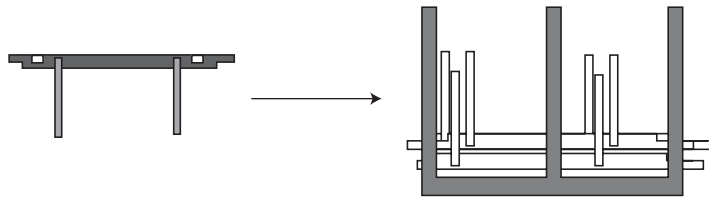

**Diagram #16**

# 11. IMPORTANT NOTICES

- A. Do not modify or alter any Hambro® product without first obtaining written approval for the desired change from the structural engineer of record and guidance from a qualified Hambro Representative.
- B. Similarly, if it becomes necessary to vary from the “APPROVED” installation drawings supplied with each job, obtain approval from the structural engineer of record prior to making the change.
- C. CAUTION... DO NOT OVERLOAD (i.e. skids of blocks, drywall, sand, mesh, etc.) slab or joist at any phase of construction.

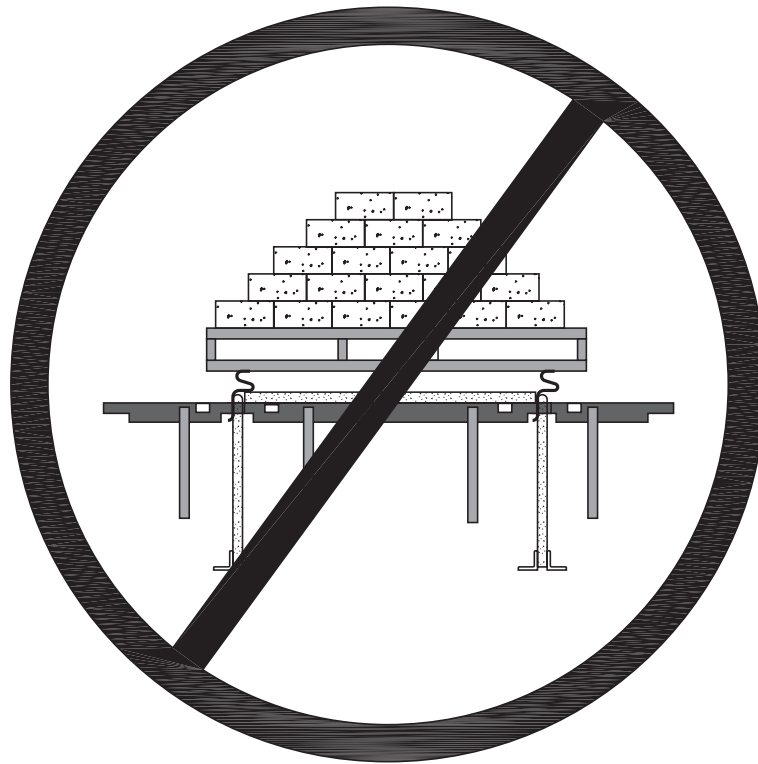

Diagram #17



Better Building **Solutions**



**United States - Main Office**

450 East Hillsboro Boulevard  
Deerfield Beach, Florida 33441  
Telephone: (954) 571-3030  
Fax: 1-800-592-4943

**Canada - Main Office**

270, chemin Du Tremblay  
Boucherville (Quebec) J4B 5X9  
Telephone: (450) 641-4000  
Fax: (450) 641-4001

**For local sales offices or distributors call: 1-800-546-9008 U.S.  
1-800-506-4000 CA**

[www.hambro.ws](http://www.hambro.ws)

A division of **Canam Group**



© Canam Group inc., 1985-2007  
© Canam Steel Corporation, 1985-2007